

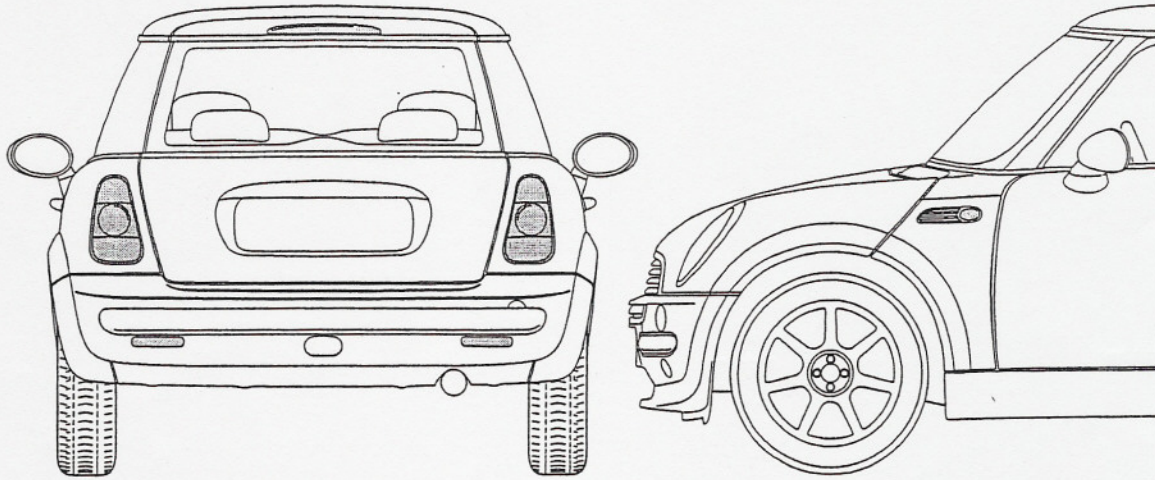

Parts and Accessories Installation Instructions



050 0126 V

White lights MINI (R50 / R53)

The installation time is approx. 0.25 hours for side lights and approx. 2.50 hours for rear lights including the third brake light and reflex reflectors, but this time may vary depending on the condition of and the equipment in the car.

When installing the kit, reflectors must also be properly installed in the rear of the vehicle to meet US lighting legal requirements in accordance with Federal Motor Vehicle Safety Standard (FMVSS) 108 (Lamps, reflective devices, and associated equipment).

Retrofit / Installation kit No. 63 12 0 140 693
63 12 0 141 252
63 12 0 142 223
63 12 0 142 518
63 12 0 146 748

Contents

Section	side
Important information	3
1. Preparations	4
2. Parts kit of additional wiring harness	5
3. Connection overview for additional wiring harness.	6
4. Additional wiring harness installation and cabling diagram	7
5. To install the additional wiring harness.	8
6. To install the reflex reflectors	10
7. Finishing work	11
8. Circuit diagram of additional wiring harness	12

Important information

The retrofit kit is for use within the MINI dealership organization only.
Separate reflex reflectors replace the reflectors in the lights (statutory regulation).
The reflector casings can be painted and can therefore be finished in the body color. Before being painted the reflector casings must be primed. Follow the BMW painting instructions.
If a rear spoiler (special equipment) is fitted, it must be raised slightly (if necessary) to replace the third brake light.

If the specified PIN chambers are occupied, bridges, double crimps or twin-lead terminals must be used. Ensure that the cables/lines are not kinked or damaged as you install them in the car. Additional cables/lines that you install must be secured with cable ties.

The MINI dealer organization cannot accept any liability for damage caused by a failure to follow the work sequence and safety instructions. In addition all warranty claims against the MINI dealer organization will be rendered void if you install and handle the product in a way other than as set out in the installation instructions and supplementary owner's handbook.

Some of the work on the car is only shown on one side. The work on the other side of the car is to be carried out in exactly the same way.

Target group

The target group for these installation instructions is specialist staff trained on MINI cars with special electric and electronic knowledge.

All servicing, repair, installation and adjustment work on cars is completed at your own risk.

All work is to be carried out using current MINI

- Repair manuals (see Technical Information System),
- Servicing handbooks
- Work instructions

in a rational sequence with the prescribed tools (special tools) and taking into account the relevant health and safety regulations.

Required special tools

None.

1. Preparations

	TIS AW-Nr.
Disconnect the battery	61 21 010
Replace the side indicator lights	63 13 210
Replace the third brake light	63 25 000
Replace the tail lights	63 21 200
Remove the following components:	
A pillar/door strut trim on both sides	51 47 000
Knee bolster on driver's side	51 16 392
Knee bolster on passenger's side	51 16 390

2. Parts kit of additional wiring harness

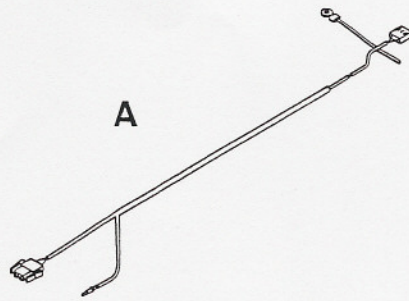

A

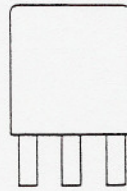

B



C

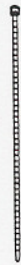

D



E

050 0329 V

Legend

A	Additional wiring harness	(1x)
B	Brake light relay	(1x)
C	Quick connector	(1x)
D	Cable tie	(10x)
E	Three position female terminal housing	(1x)

3. Connection overview for additional wiring harness

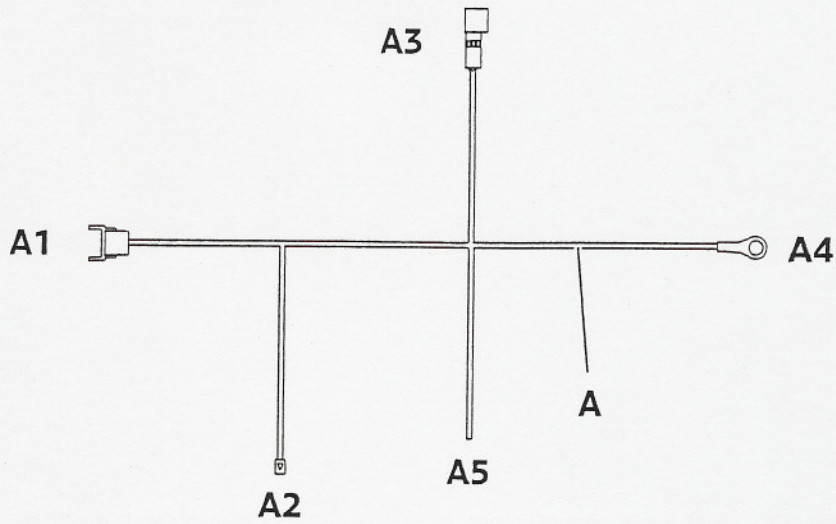

050 0325 V

Item	Description	Signal	Cable colour / Cross-section	Connection location in the car	Abbreviation / Slot
A	Additional wiring harness	---	---	---	---
A1	Relay base	---	GN/GE GE/BR GE/SW SW/BL BR	Driver's footwell	X003
A2	Female terminal for fuse 36	KL. 15	GN/GE	At the blue, 12 position connector housing at the fuse box A47	X10205 PIN 10
A3	Black, three-position pin housing	---	GE/BR GE/SW	Passenger's footwell by Body Control Module (BCM)	X001
A4	Ring cable lug	KL. 31	BR	Ground connection	X151
A5	Open contact	---	SW/BL	Brake Light signal - Quick connect to PIN 12 X254	X002

4. Additional wiring harness installation and cabling diagram

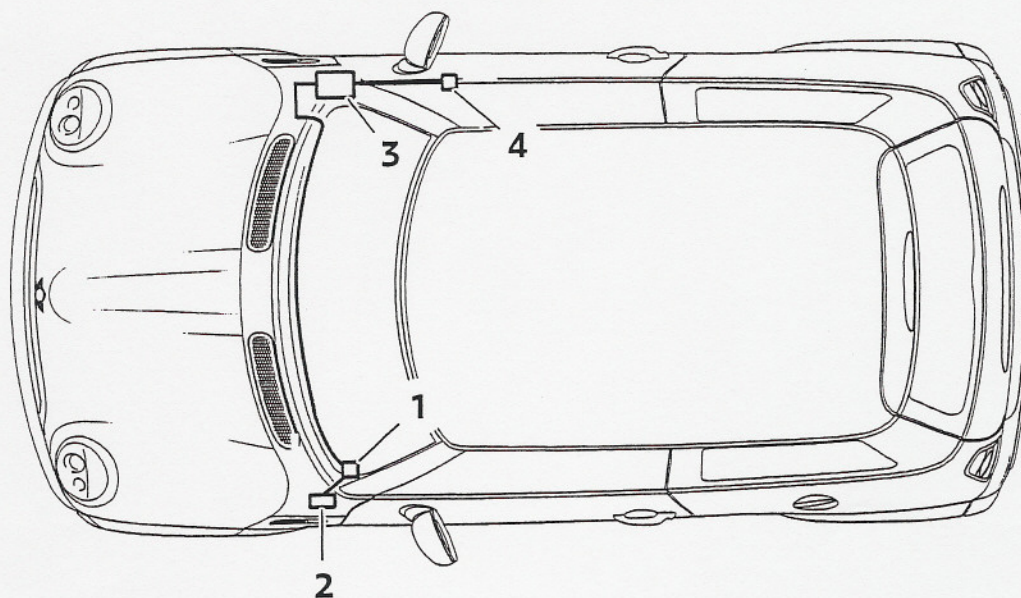

050 0324 V

Legend

- 1 Brake light relay
- 2 Fuse box
- 3 Body Control module (BCM)
- 4 Ground Connection

5. To install the additional wiring harness

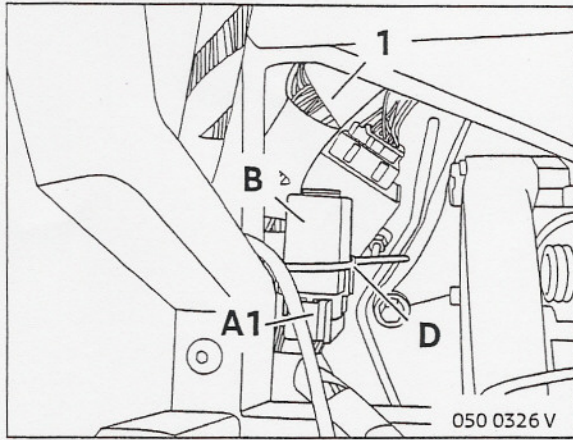

Insert brake light relay **B** into socket **X003 A1**. Place the relay **B** next to the wire harness (1) located in the corner of the driver's footwell and secure with a cable tie **D**.

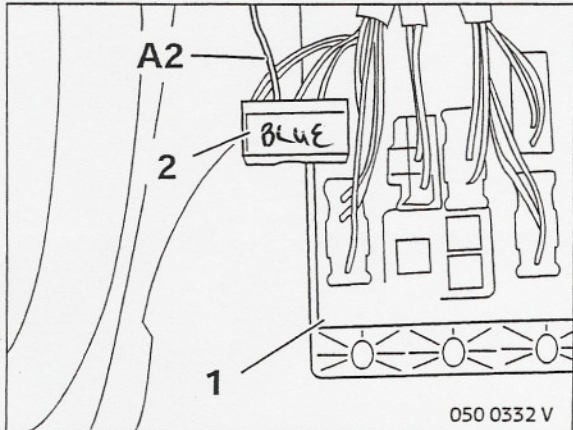

Picture 050 0332 V shows fuse box **A47** (1) from behind with unplugged connector housing **X10205** (2).

Lay branch **A2** (color GN/GE) on the additional wiring harness **A** to the fuse box **A47** (1). Insert branch **A2** in blue 12 position female terminal **X10205** (2) PIN 10.

Route additional wiring harness **A** behind the center console to Body Control Module (BCM) in passenger's footwell.

☐ Ensure that the cable is laid cleanly (secure harness **A** with cable ties **D**). ◀

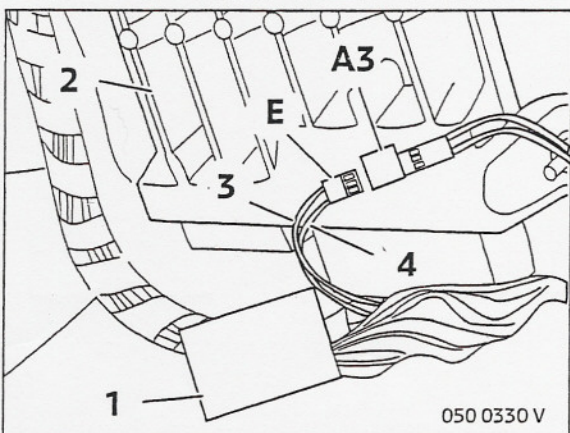

Disconnect 54-pole white plug **X254** (1) from the Body Control Module (BCM) (2).

Unplug contact (3), color GE/BR, PIN 15 and insert into terminal housing **E**, PIN 1.

Unplug contact (4), color GE/SW, PIN 17 and insert into terminal housing **E**, PIN 3.

Lay branch **A3** (color GE/BR, GE/SW) to the Body Control Module (BCM) (2).

Connect pin housing **A3** and terminal housing **E** together.

Reconnect **X254** to the Body Control Module (BCM) (2).

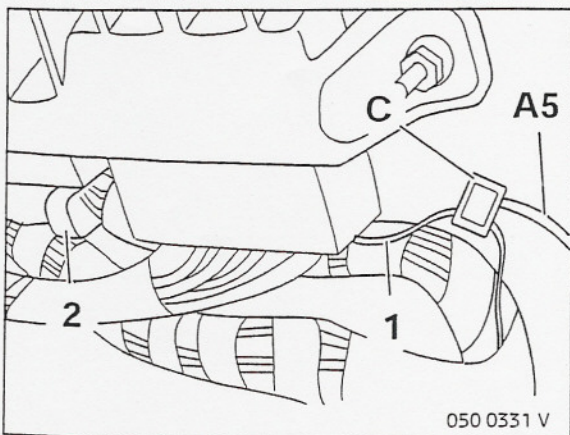

Connect the SW/BL wire/lead **A5** to the SW/BL wire (1) coming from pin 12 of the white 54 pin Body Control Module (BCM) connector **X254** (2), using a quick connect **C**.

5. To install the additional wiring harness

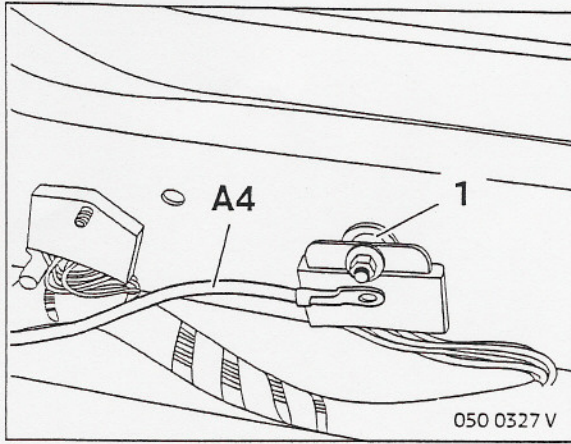

Connect wire/lead **A4** from the additional wiring harness to the ground point **X151 (1)** located along the right side skirt.

6. To install the reflex reflector



When installing the kit, reflectors must also be properly installed in the rear of the vehicle to meet US lighting legal requirements in accordance with Federal Motor Vehicle Safety Standard (FMVSS) 108 (Lamps, reflective devices, and associated equipment) ◀



Only use the templates of the original installation kit, in other words do not use copies. ◀

Cut out the templates **precisely** along the marked lines.

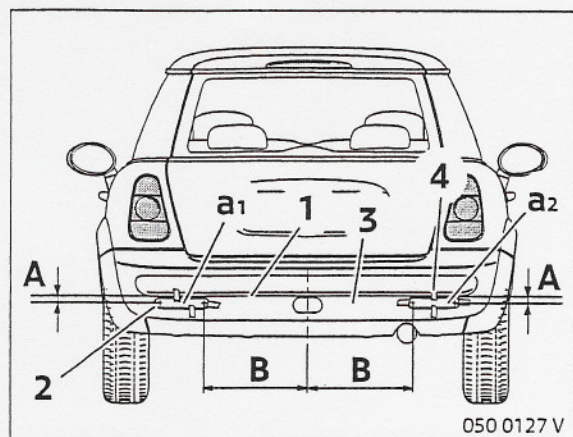

Standard bumper:

Mask the whole of the working area to protect the bumper. Position the template a_1 at a distance of $A = 29.5 \text{ mm}$ between the bumper joint (1) and the cross (2) on the bumper (3). At the same time check the distance $B = 390 \text{ mm}$ from the center of the car to the inner cross. Secure the template with several strips of adhesive tape (4) (remove some of the strips of adhesive tape temporarily). Position template a_2 in the same way.

Mark the marking for the recess for the reflector casing on the bumper (3) along the outer contour of the templates a_1 and a_2 .

Drill a starting hole for the compass saw at a safe distance from the marking, within the contour, using a drill bit. Carefully cut out the recess.

Check the size of the recess by positioning the reflector casing. If necessary finish the recess with a semi-circular file.

Insert the reflector casing with the word „TOP“ at the top. As you fit it ensure that it is correctly positioned. To do this insert the casing at the bottom and then press it in at the top.

Remove the backing foil from the rear of the reflex reflector. Affix the reflex reflector in the reflector casing with the word „TOP“ at the top.

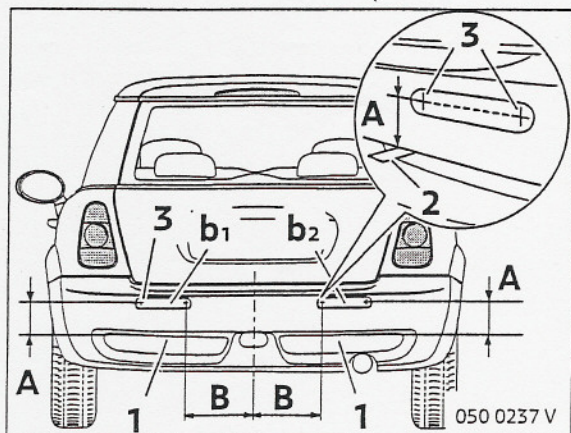

Aerodynamic package bumper and Cooper S:

The reflector casings must be installed in the aerodynamic package bumper and Cooper S using templates b_1 and b_2 . The work is to be conducted in the same way as that for the standard bumper. Mark dimension A as follows: Place a stop (2) on the top surface of the immersion (1). From the top edge of the stop (2) measure dimension A to the crosses (3) on the templates b_1 and b_2 . Dimension $A = 102 \text{ mm}$ for the aerodynamic package bumper, dimension $A = 98 \text{ mm}$ for the Cooper S bumper.

Dimension $B = 303 \text{ mm}$ for the aerodynamic package bumper and the Cooper S bumper.

7. Finishing work

- Connect battery
- Make function test: When using the brakes, the rear fog lights must be illuminated parallel to the brake lights
- Reassemble the car the opposite way round



This retrofit kit does not have to be coded. ◀

8. Circuit diagram of additional wiring harness

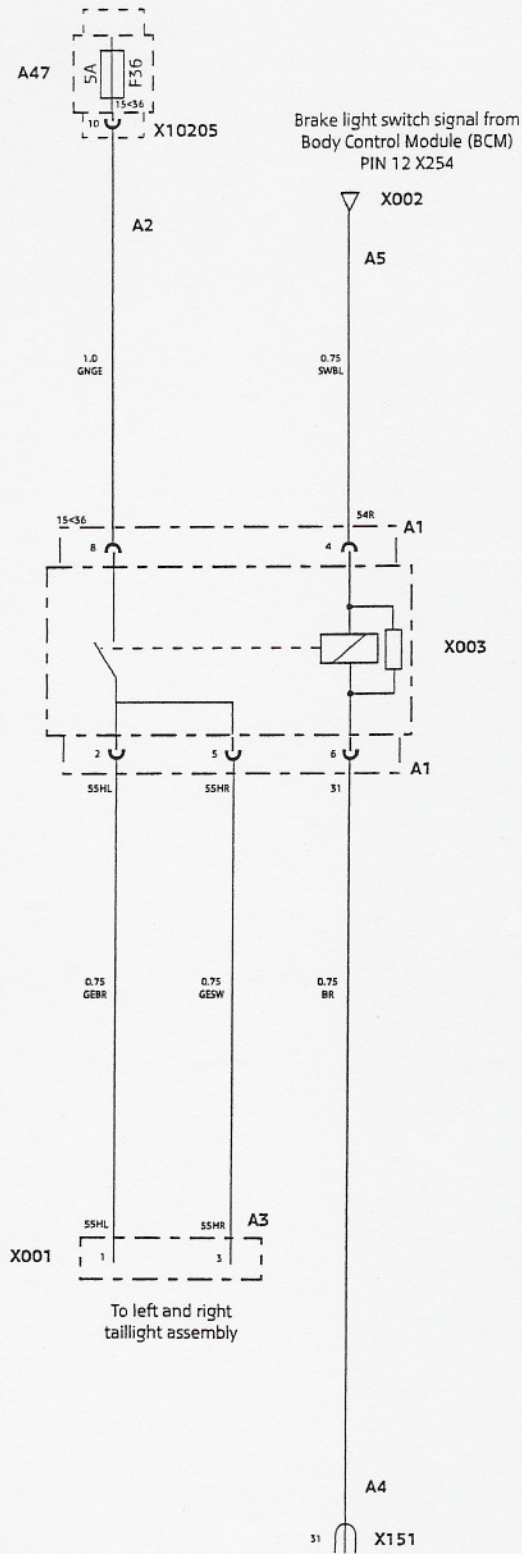

050 0360 V

8. Circuit diagram of additional wiring harness

Legend

A47	Fuse box
X10205	Blue 12 position connector housing
X151	Ground connection
X001	Three-position pin housing to taillight assembly
X002	Connection for brake light switch signal (Quick Connect)
X003	Connector for Brake light relay

Cable colors

GN	green
GE	yellow
BR	brown
SW	black
BL	blue