



Installation Instructions

Accessories, Armrest

Page 1 of 8

December 2003

Product
Development

SUBJECT

Armrest Retrofit Kit P/N 82 12 0 304 181

MODEL

Cooper & Cooper S (R50/R53): All Vehicle Production

SUGGESTED INSTALLATION TIME: 1 hour.

These instructions were developed especially for MINI vehicles and are not to be compared to any existing instructions for vehicles other than MINI. No methods other than those specified in this document are to be used to install this **armrest retrofit kit**.

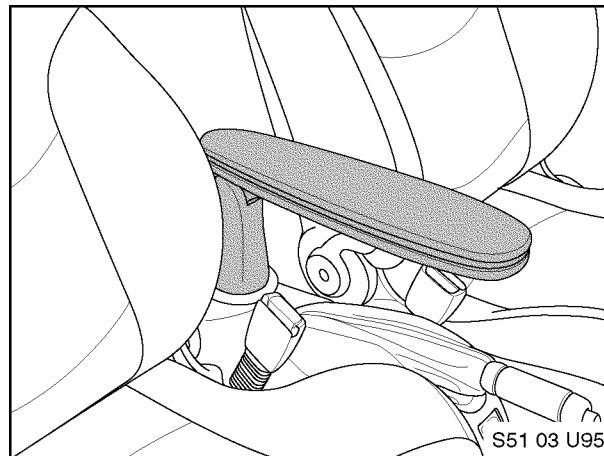

★ ★ DO IT RIGHT THE FIRST TIME, ON TIME, EVERY TIME ★ ★

Installation Instructions PN 01 00 0 307 138

MINI, a division of BMW of North America, LLC

© 2003 BMW of North America, LLC

PARTS INFORMATION**Contents of Kit – P/N 82 12 0 304 181**

Parts Description	Qty	Part Number
Armrest with keeper screws	1	NA
Armrest base assembly	1	NA
Cover	1	NA
M16x56mm hex standoff with center		
M6x1.0 pitch tapped hole	2	NA,
M6x20mm hex head bolt	4	NA
M6 split lock washer	4	NA
10-32x1-1/2" Phillips flat head screw	4	NA
M6 flat washer (shims)	6	NA
Thread lock .5ml tube	1	NA

REQUIRED ADDITIONAL PARTS FOR NON DSC EQUIPPED VEHICLE (to be ordered separately)

Parts Description	Qty	Part Number
DSC sensor bracket	1	34 51 6 757 388
M8 self-locking hex nut with flange	3	31 33 0 141 304

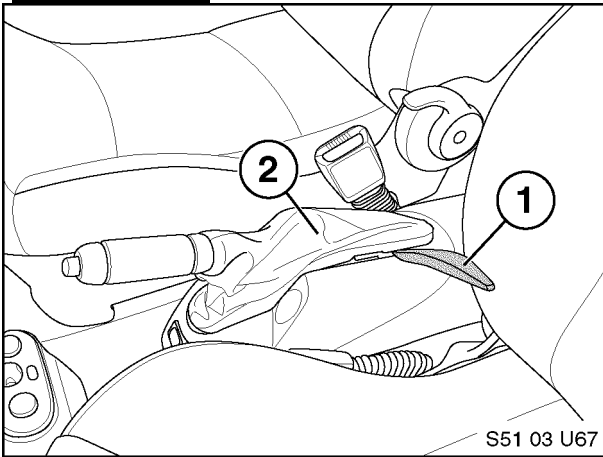
PROCEDURE:

1. Use trim removal tool (1) to carefully pry out handbrake surround trim piece (2) as shown.

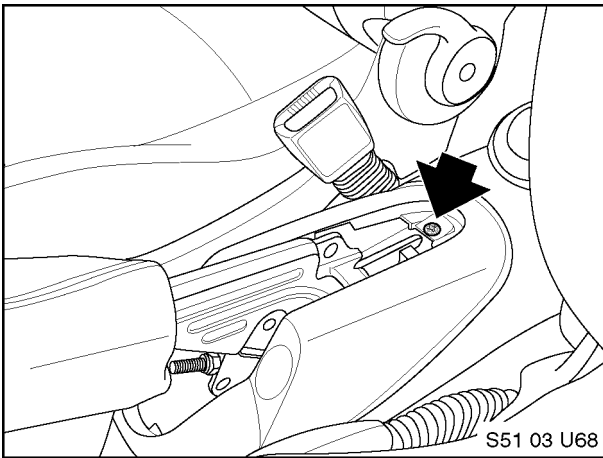

2. Remove Phillips® head self-tapping screw (black arrow).

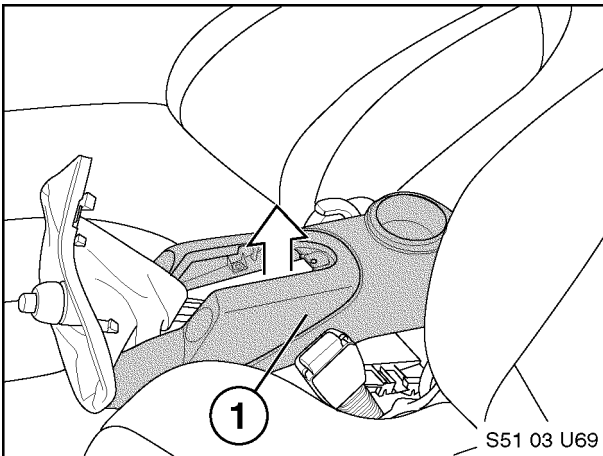

3. Grasp center console (1) and pull upwards to unlock retaining clips.

Disconnect flat tire monitor control switch (if equipped).

Direct handbrake surround trim piece inward through opening of center console and remove center console from vehicle.

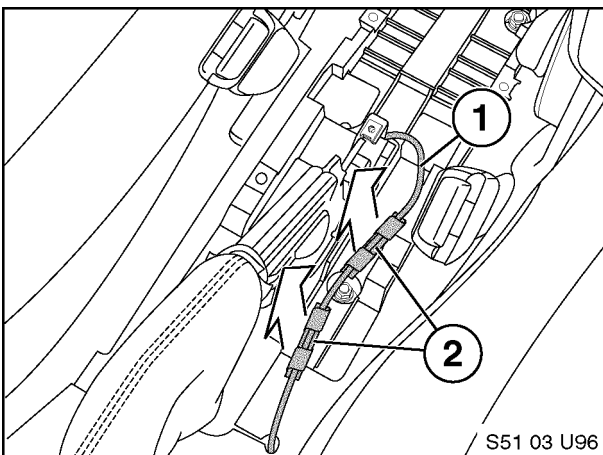

For Vehicles with DSC proceed to step 8.

For Vehicles without DSC, it will be necessary to perform the following steps.

4. Disconnect handbrake warning lamp harness connector (1). Carefully pry up on harness retainers (2).

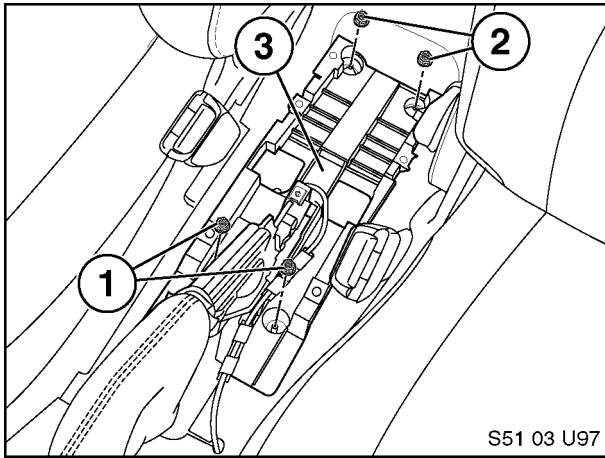

4

- Remove front pair (1) and rear pair (2) M6 nuts. Temporarily remove console support bracket (3).

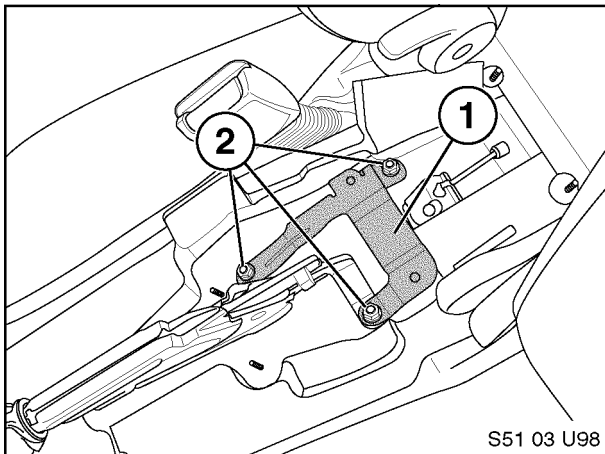

- Locate proper position of DSC sensor bracket (1). It will be necessary to remove the two rear-most existing M8 self-locking hex nuts (2) before installing DSC sensor bracket (1) onto M8 mounting studs.

Secure bracket (1) in place using new (**do not reinstall original nuts**) M8 self-locking hex nuts (2) as shown.

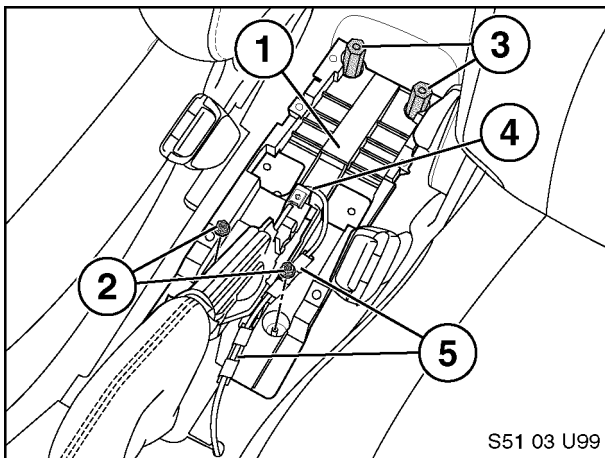

- Reinstall console support bracket (1). Reinstall front pair M6 nuts (2). Install kit-supplied pair of M16x56mm hex standoffs (3) on threaded M6 studs as shown.

Connect handbrake warning harness connector (4). Reinstall harness retainers by pressing them into position (5) as shown.

Proceed to step 9.

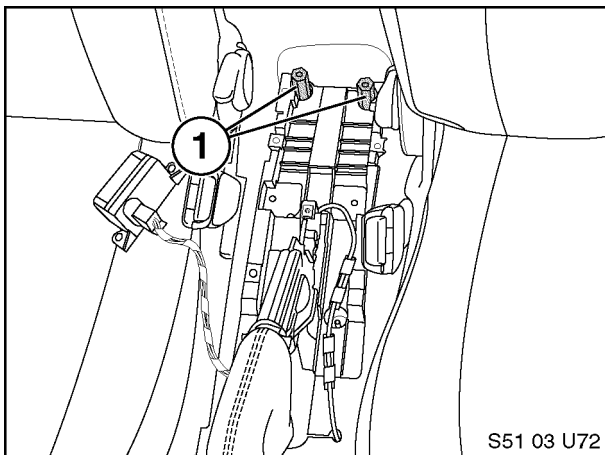

- Install pair of M16x56mm hex standoffs (1) on threaded M6 studs as shown.

5

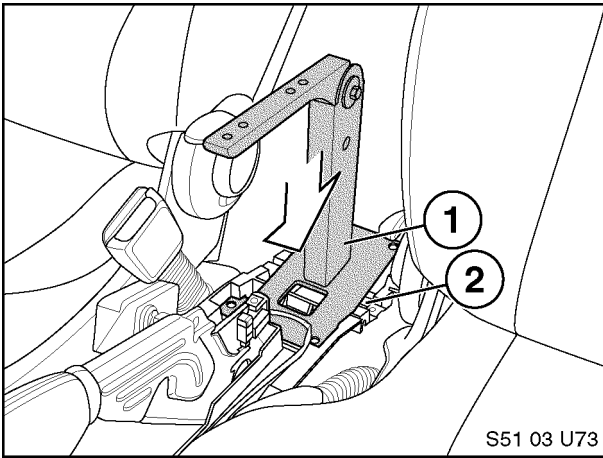

9. Test fit armrest base assembly (1) onto console support bracket (2) to determine where interfering material on console support bracket must be removed to achieve levelness and stationary fit of armrest base assembly.

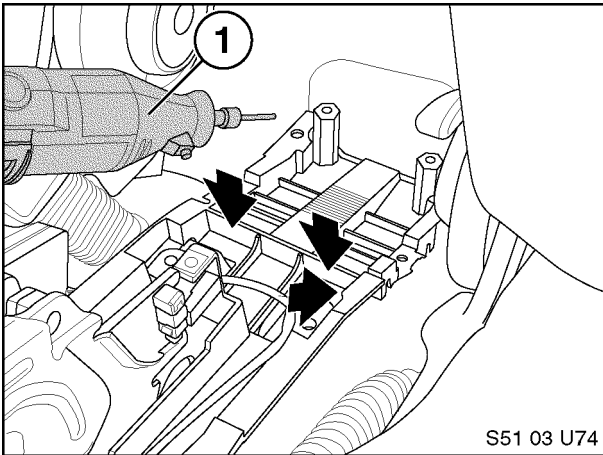

10. Remove any interfering material (black arrows) from console support bracket as necessary by using a Dremel® (1) or similar rotary tool with a grinding bit as shown.

Continue to test fit armrest base while removing interfering console support bracket material until desired fit has been achieved. Forward armrest base mounting holes must align with tapped holes in DSC mounting bracket. Rearward armrest base mounting holes must align with tapped hole in each hex standoff.

Vacuum up grinded console support bracket material debris before proceeding with this installation.

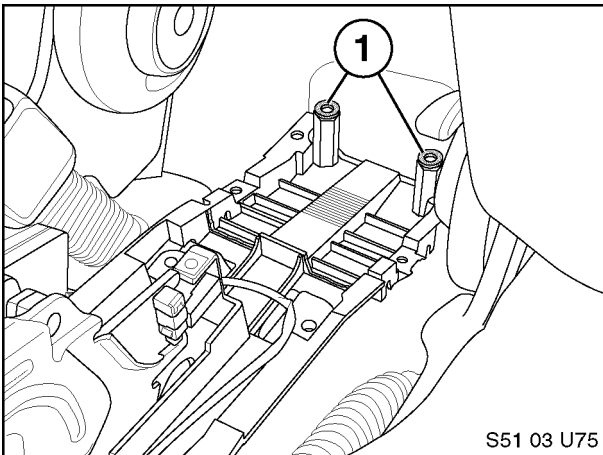

11. Test fit armrest base assembly to console support bracket/hex standoffs assembly for levelness. Install M6 flat washer(s) (1) as shims on top of hex standoff (1) as necessary to achieve levelness.

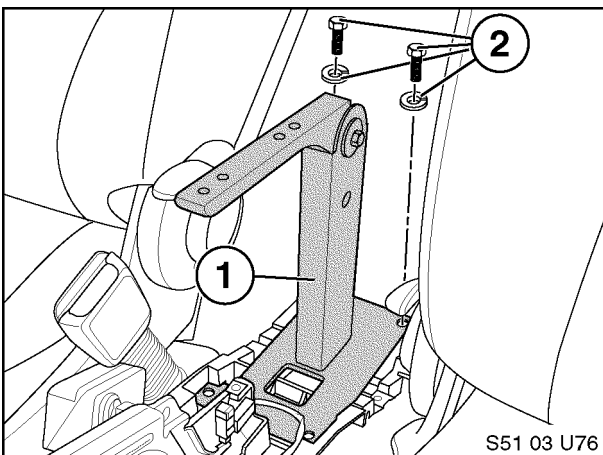

12. Secure armrest base (1) to hex spacers using M6x20mm hex head bolts with M6 split lock washers (2) as shown.

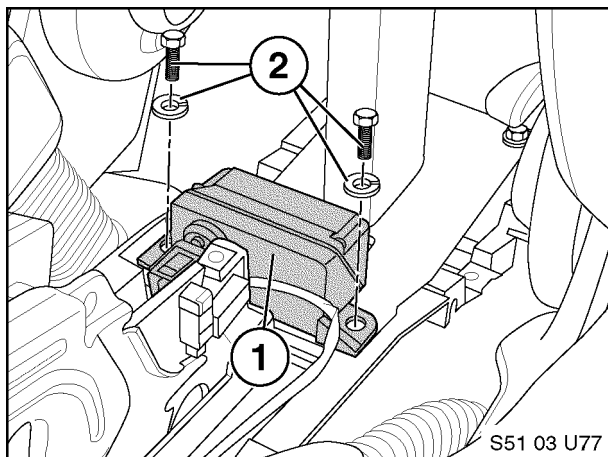

For Vehicles with DSC

Install DSC module in place with mounting holes aligned with forward pair of holes on armrest base. Secure DSC module (1) and forward armrest base in place with kit supplied M6x20mm bolts with lock washers (2) as shown. **Note: Original DSC module mounting bolts can be discarded.**

For Vehicles without DSC

Secure forward part of armrest base to console support bracket with M6x20mm hex head bolts and lock washers (2).

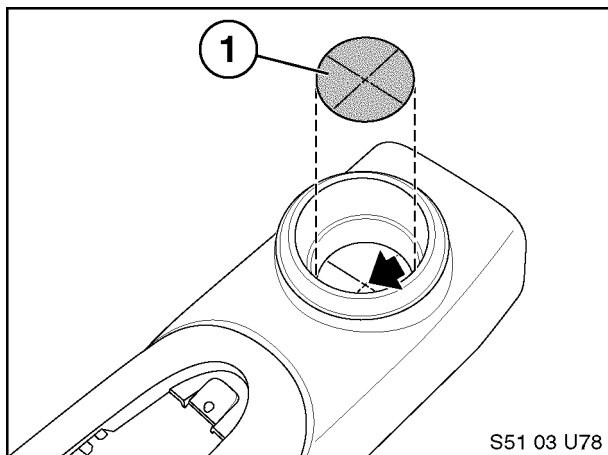

13. Print out template found on last page of these installation instructions. Follow instructions on bottom of template page to achieve proper template size. Carefully cut out template.

Position template (1) to bottom of center console cup holder opening as shown. Mark center position of cup holder opening with center punch.

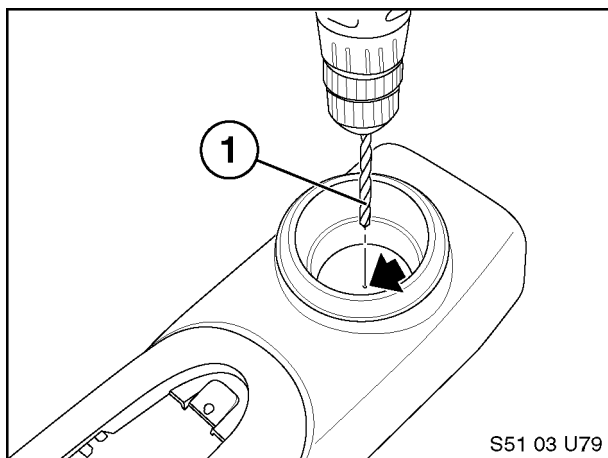

14. Use a 3/16" (5mm) diameter drill bit to make a pilot hole as shown.

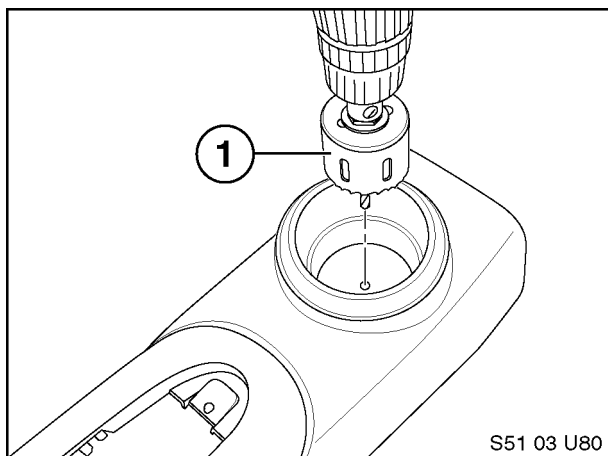

15. Use a 2-1/4" (57mm) diameter hole saw to drill out access hole as shown.
16. Pull up on handbrake to fully applied position. Position center console to armrest so that armrest pivoting bracket passes through access hole until vertical post protrudes upward through access hole.

Direct handbrake surround trim piece outward through oval opening of center console.

17. Reconnect flat tire monitor control switch mating connectors (if equipped).
Position center console in place and push down on rear, center and forward areas of center console to attach mounting clips into position (an audible click should be heard as each clip is seated).

Install Phillips® head self-tapping screw.

Position handbrake surround trim piece in place

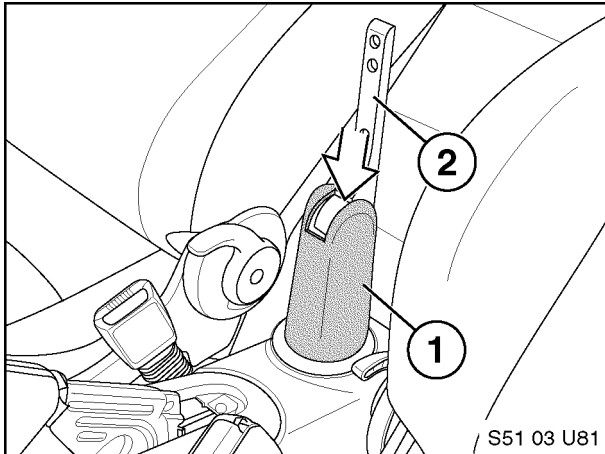

18. Direct cover (1) over pivoting arm bracket (2) and position cover in vertical position as shown.

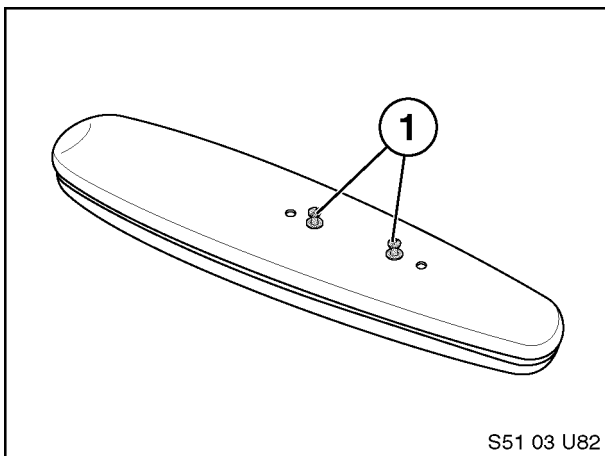

19. Remove "keeper screws" and flat washers (1).

Note: "Keeper screws are only intended for use during initial factory assembly setup procedure. These screws are of insufficient length for the following step and should be discarded."

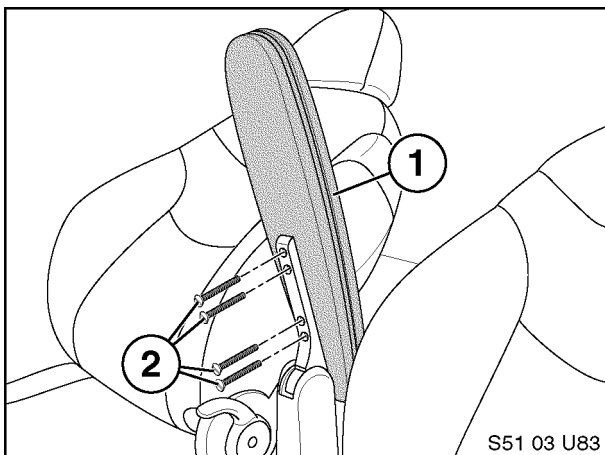

20. Apply a small amount of liquid thread lock supplied in the kit to each of the 4 -10-32x1-1/2" long flat head screws.

Position armrest (1) to pivoting arm bracket and secure in place with 10-32x1-1/2" flat head screws (2) as shown.

Install the 4 plugs over each hole (dome side out) and set in place with a small soft face or plastic tip hammer.

TEMPLATE FOR MINI CENTER CONSOLE ARMREST CUT OUT

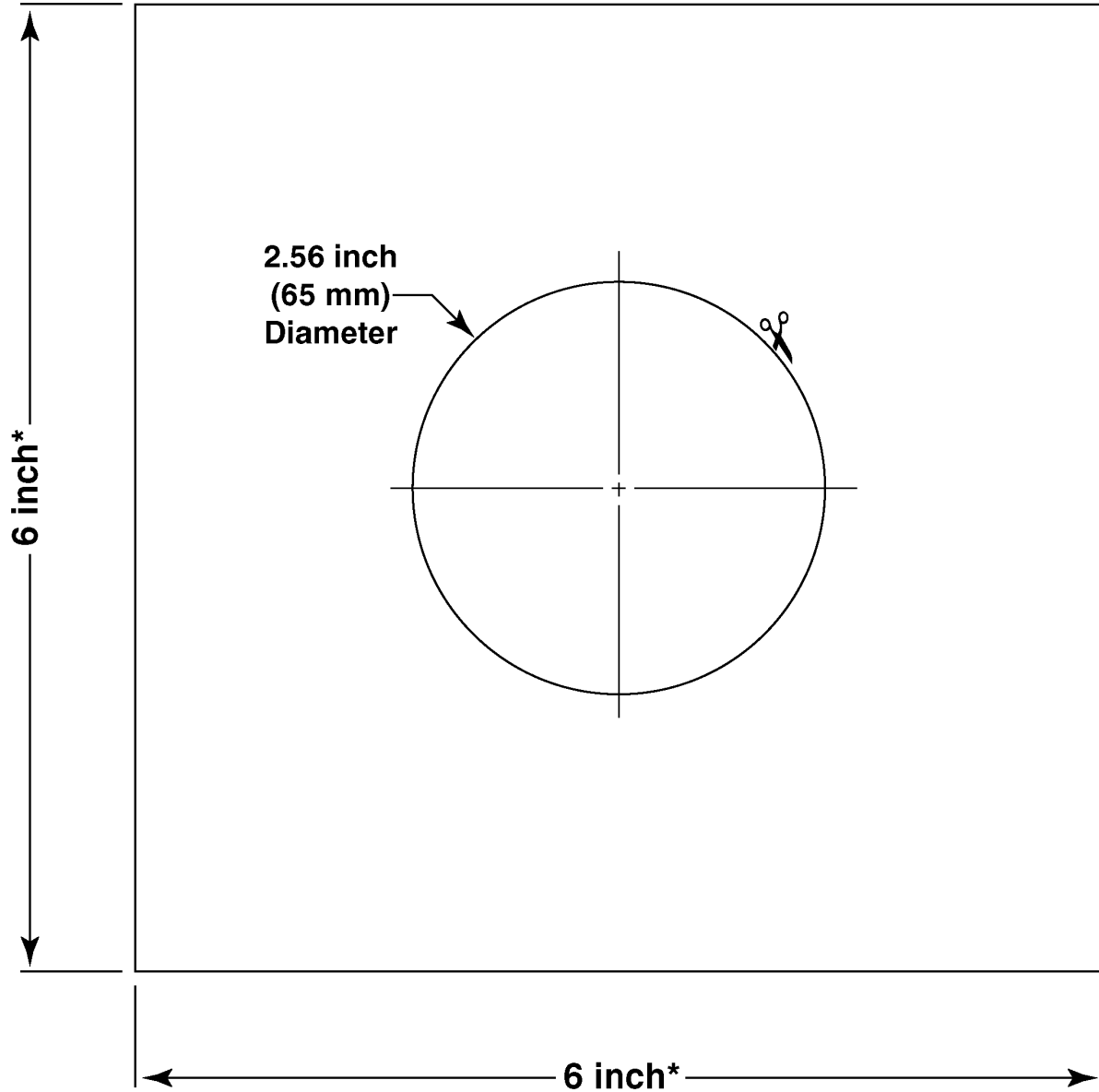

*** THIS 6 INCH SQUARE RECTANGLE IS A REFERENCE GUIDE TO ASSIST YOU TO PRINT OUT THE TEMPLATE ACCURATELY. PRINT THIS PAGE, THEN MEASURE THE RECTANGLE, ALL [4] SIDES OF THE RECTANGLE MUST BE 6 INCHES LONG. IF THE RECTANGLE IS NOT 6 INCHES SQUARE, ADJUST YOUR PRINTOUT TO PRINT THIS PAGE CORRECTLY, OR CREATE YOUR OWN TEMPLATE TO THE SPECIFICATIONS INDICATED.**