



Installation Instructions

Page 1 of 7

March 2004

Universal Accessories, Bike Holder

Accessory
Development

SUBJECT

MINI LINK SYSTEM BIKE HOLDER – P/N 82 11 0 154 540

MODEL

Cooper (R50) and Cooper S (R53)

All Vehicle Production

SUGGESTED INSTALLATION TIME:

ASSEMBLY OF RACK – 0.5 HOURS

MOUNTING ON VEHICLE – 0.1 HOURS

These instructions were developed especially for MINI vehicles and are not to be compared to any existing instructions for vehicles other than MINI. No methods other than those specified in this document are to be used to assemble or install the **MINI Link System Bike Holder**. Read all instructions and procedures before beginning assembly and installation. Those instructions dealing with a stock part of the vehicle, but not stated in detail, should be referenced in the BMW web based vehicle repair manual. Left and right are determined from the drivers seat.

Note: If the dealer installs the MINI Link System Bike Holder, a copy of these installation instructions must be given to the customer.

★ ★ DO IT RIGHT THE FIRST TIME, ON TIME, EVERY TIME ★ ★

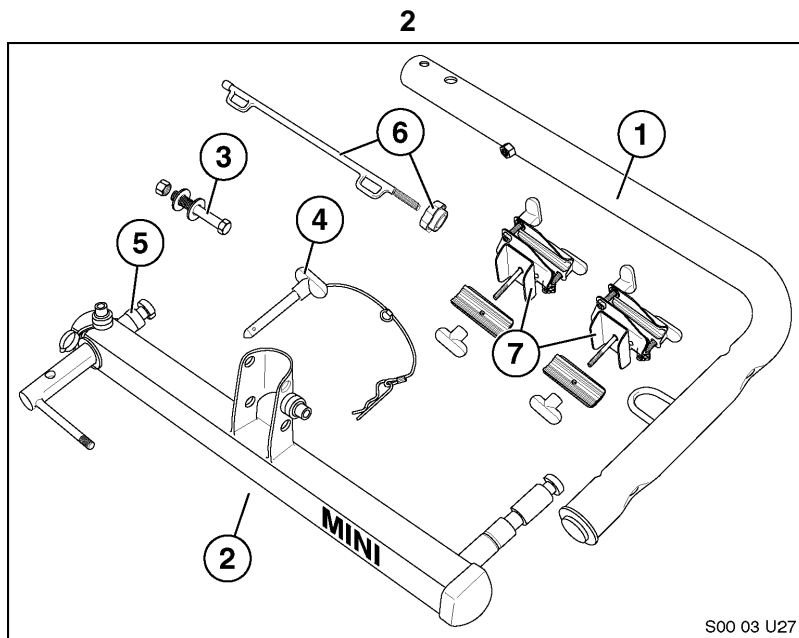

PARTS INFORMATION

Contents of Kit – P/N 82 11 0 154 540

| Reference Number | Description | Qty | MINI Part Number |
|-------------------------|---|------------|-------------------------|
| 1 | Pivoting Bike Holder Arm | 1 | Not Available |
| 2 | Base Support Bar Assembly with Dual Security Locks | 1 | Not Available |
| 3 | Pivot Arm Bolt, Plastic Washers, and All Metal Lock Nut | 1 | 82 11 0 392 303* |
| 4 | Pivot Arm "T" Handle Pin with Lanyard and Clip | 1 | 82 11 0 392 305* |
| 5 | Left Side Rotating Locking Pin | | Not Available |
| 6 | Tie-Down Strap Arm with Locking Knob | 1 | 82 11 0 392 306* |
| 7 | Bike Holding Clamp | 2 | 82 11 0 392 308* |
| Not Pictured | Rubber Weather Protection Covers for Security Locks | 2 | 82 11 0 305 157* |
| Not Pictured | Nylon Tie-Down Straps | 2 | 82 11 0 392 418* |
| Not Pictured | Barrel Keys (for security locks) | 2 | See MINI Dealer* |

*These replacement parts are available at your local MINI Dealer.

Additional Required Parts

| Description | MINI Part Number |
|-------------------------------|-------------------------|
| MINI Link System Sport Link** | 82 11 0 154 539 |

**Use of the MINI Link System Bike Holder requires the vehicle be equipped with the MINI Link System Sport Link.

Bike Holder Guidelines and Cautions

When using the MINI Link System Bike Holder, the user must understand and follow the precautions listed below.

The following points will help you install and use the MINI Link System Bike Holder safely:

- Make sure all knobs, bolts, screws, straps, and locks are firmly attached, tightened and locked before every trip. Knobs, bolts, screws, straps, and locks must be periodically inspected for proper tightness, signs of wear, corrosion, and fatigue.
- Check your load at stops during the trip to ensure continued fastening security.
- Check local and state laws governing the projection/extension of objects beyond the width of a vehicle. Check local and state laws governing the extension/overhang of objects beyond the rear of a vehicle.
- Be aware of the width, height and extension to the rear of your load. Even minor contact with fences, posts, bridges, other objects or vehicles can adversely affect the load.
- For your safety, and the safety of your vehicle and rack system, obey all posted speed limits and traffic cautions. Adapt your speed to the conditions of the road and the load being carried.
- Any load will affect the vehicle's driving and handling behavior. Never drive with any lock, knob, strap, clamp or rack component in an open or unlocked position. Never drive with any load that is not securely fastened.
- Remove the bike holder and accessories when they are not in use and before entering automatic car washes.
- Locks are designed to deter vandalism and theft. Replacement keys are available only through your authorized MINI dealer. A security loop has been provided on the pivoting bike holder arm to facilitate the installation of an optional bicycle cable lock. Remove valuable gear if your vehicle is left unattended for an extended period.
- All locks must be turned and moved periodically to ensure smooth operation. Use graphite or dry lubricant to ensure trouble free operation.
- Do not use the MINI Link System Bike Holder for purposes other than those for which it was designed. Do not exceed the carrying capacity (2 bikes). Failure to follow these guidelines or the product's instructions will void the warranty.
- Consult with your MINI dealer if you have any questions regarding the operations and limits of this product. Review all instructions and warranty information carefully.

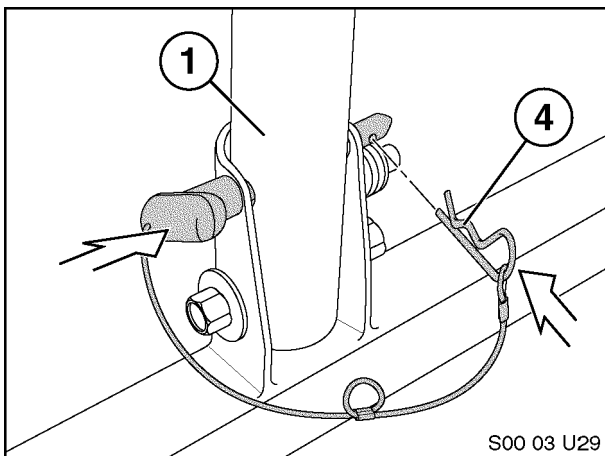
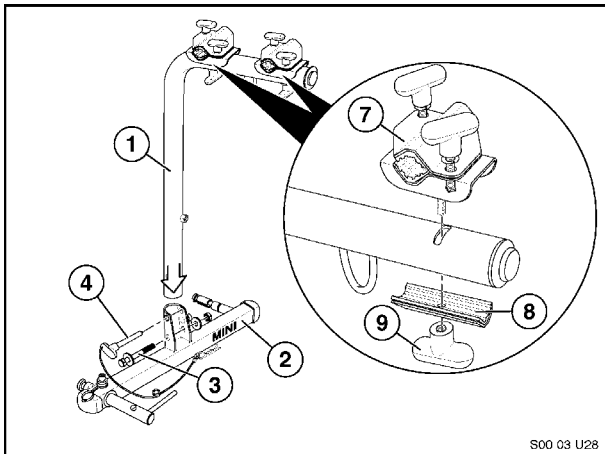
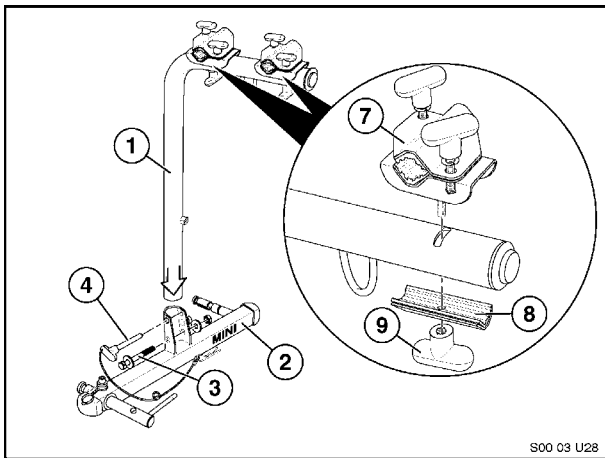
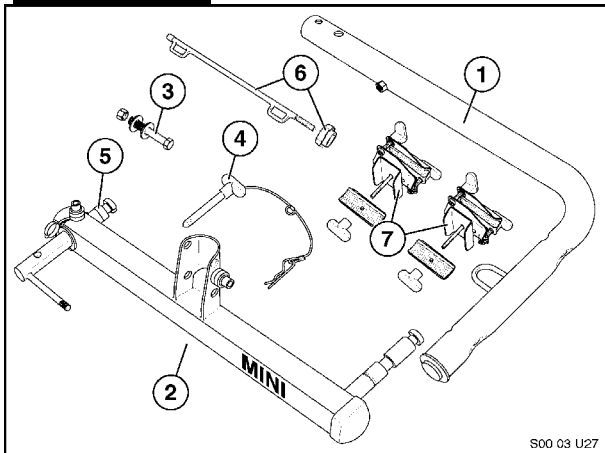
PROCEDURE:

1. Locate and remove parts from shipping container.
 - (1) Pivoting Bike Holder Arm
 - (2) Base Support Bar Assembly with Dual Security Locks
 - (3) Pivot Arm Bolt, Plastic Washers, and All Metal Lock Nut
 - (4) Pivot Arm "T" Handle Pin with Lanyard and Clip
 - (5) Left Side Rotating Locking Pin
 - (6) Tie-Down Strap Arm with Locking Knob
 - (7) Bike Holding Clamps

Not Illustrated – 2 Nylon Tie-Down Straps (36"x1")
2 Barrel Keys (for security locks)

2. Insert Pivoting Bike Holder Arm (1) into Saddle of Base Support Bar (2) as illustrated. Align Holes in Saddle and Arm.
3. Insert Pivot Arm Bolt (3) with plastic washer through lower holes in saddle and pivot arm. Install second plastic washer and Lock Nut onto bolt. Position/Tighten lock nut ensuring that lock nut provides a snug fit against nylon washers without crushing washers or binding Pivot Arm.
4. Insert Pivot Arm "T" Handle Pin (4) through upper holes in saddle and arm to hold pivot arm in place. Reference illustration S00 03 U29 below.
5. Position Bike Holding Clamp (7) on topside of pivot arm so that threaded mounting stud is fully inserted through upper and lower slots in bike holding arm.
6. Install lower Clamp Pad (8) and Knob (9) onto threaded mounting stud.
7. Tighten knob to hold clamp assembly in place.
8. Repeat sequence above for second bike holding clamp.
9. With Pivot Arm "T" Handle Pin inserted through saddle and pivot arm as illustrated, insert clip (4) through hole in pin so that clip is fully seated in "locked" position.

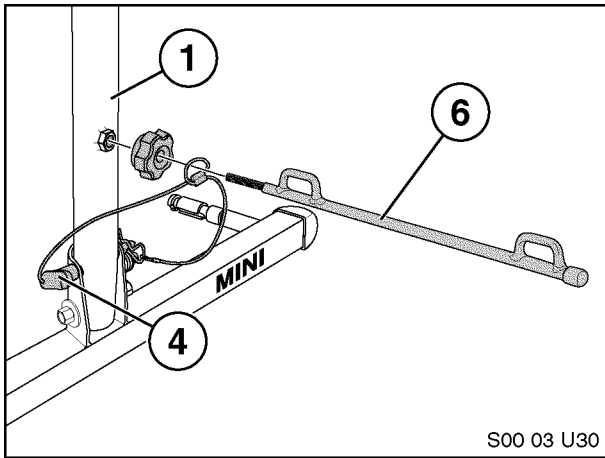

10. Install Tie-Down Strap Arm (6) onto Pivot Arm (1) as illustrated.

Note: Loop in center of pivot pin lanyard should be inserted over end of strap arm before locking knob is threaded onto strap arm.

11. Tighten locking knob to hold strap arm in place.

Note: Strap arm can be positioned with strap loops in any position to suit bicycle type being carried.

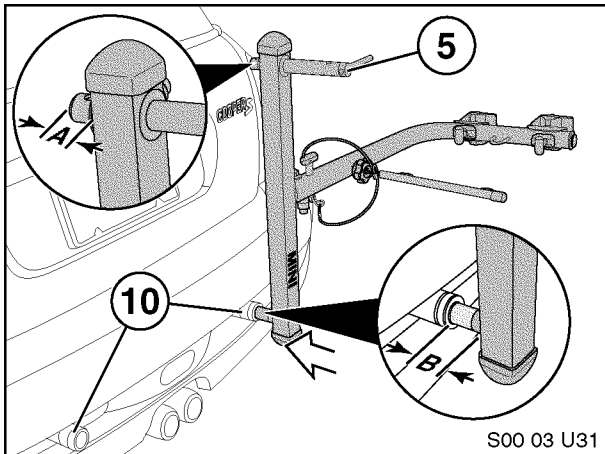

12. Install Bike Rack on vehicle as follows:

13. Position Bike rack as illustrated. Insert stationary pin into right side Sport Link socket (10).

14. Insert pin to depth marked by INSERT TO HERE decal on pin. Approximately 57mm (2 1/4") of pin will remain exposed (B) when pin is installed to correct depth.

15. Pull Rotating Locking Pin (5) to the rear. Approximately 19 mm (3/4") of pin will protrude from bar (A) when pin is fully retracted.

16. Carefully rotate Bike Rack to the left.

Note: Make certain Rotating Locking Pin will clear bumper of vehicle.

17. Align rotating locking pin with left side Sport Link socket. With handle pointing up push locking pin into socket as far as it will go.

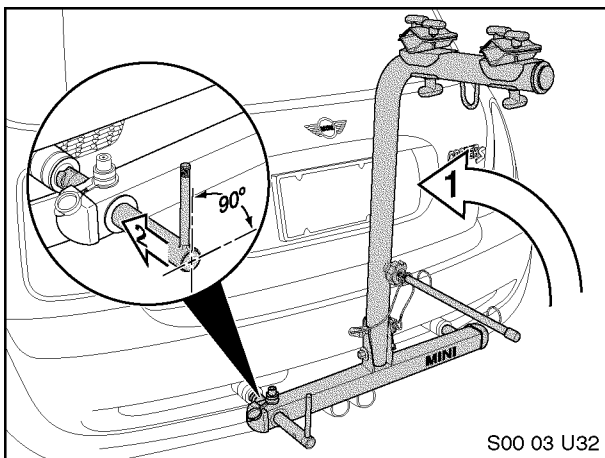

18. With pin fully inserted, rotate handle 90 degrees to the right to lock pin in place.

19. Push down on security lock to secure rotating locking pin in place.

Note: Place Weather Protection Cover on lock to protect lock mechanism from the elements.

20. Confirm proper installation of rack by pulling Base Support Bar rearward. There should be no rearward movement of bar and both left and right pins should be held securely in place.

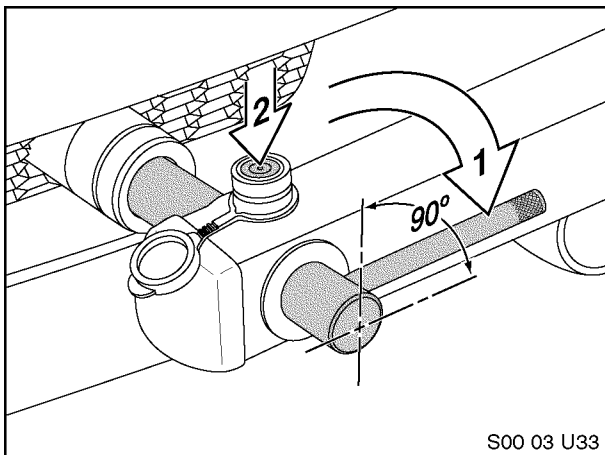

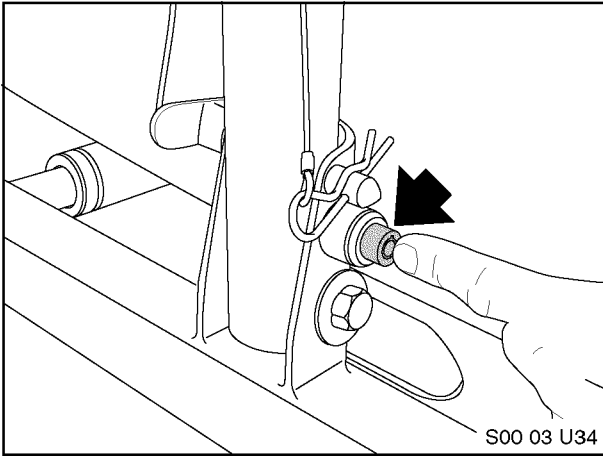

21. To lock Pivot Arm in place push security lock inward as illustrated.

Note: Place Weather Protection Cover on lock to protect lock mechanism from the elements.

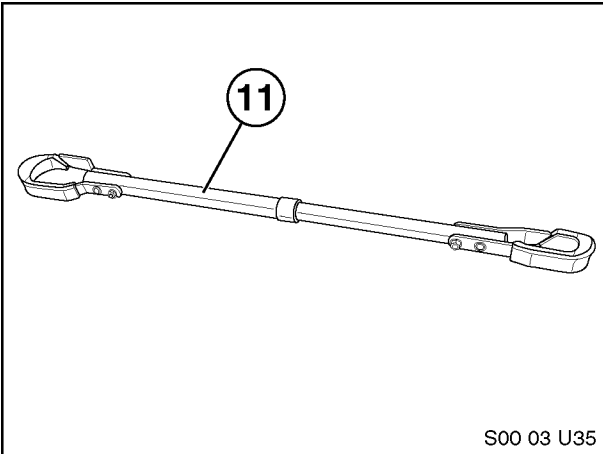

22. A Bike Frame Adapter (11) is available from your dealer for use on bikes without traditional upper frame tubes.

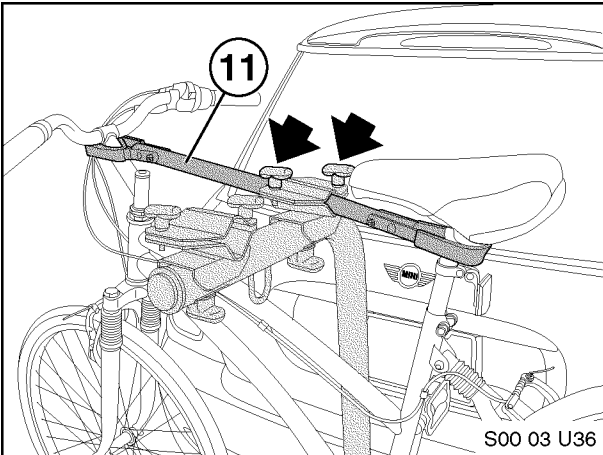

23. Mount bicycle with upper frame tube or frame adapter (11) cradled in Bike Holding Clamp as illustrated.

Note: It is only necessary to fully remove one upper clamp knob (knob without black plastic stop) from lower clamp plate in order to swing upper clamp plate aside and position bike frame onto lower clamp plate.

24. Tighten both upper clamp knobs (black arrows) evenly and only tight enough to hold bike securely in place.

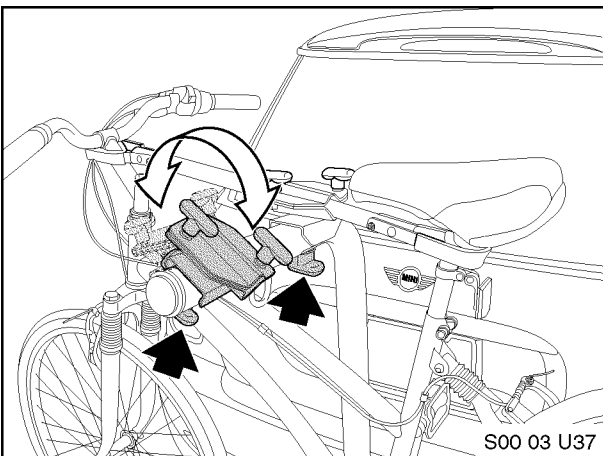

25. To change relative position of bicycle on rack, loosen lower clamp knob (black arrows) and rotate bike clamp assembly left or right.

26. Tighten lower clamp knob securely to hold clamp in new position.

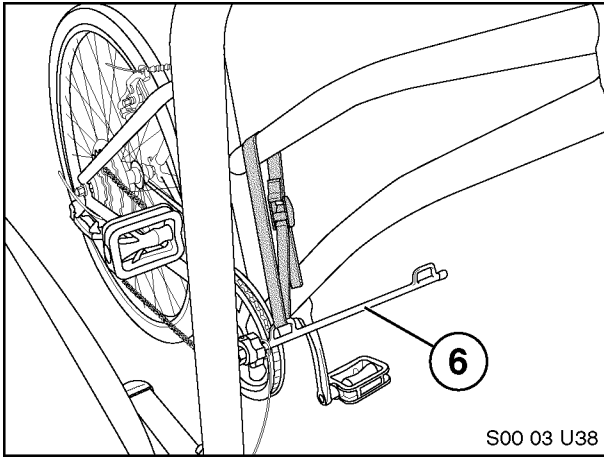

27. Secure lower section of bike frame to rack using nylon straps routed around bike frame and through Tie-Down Strap Arm (6) loops.

Note: Strap arm can be positioned with strap loops in any position to suit bicycle type being carried.

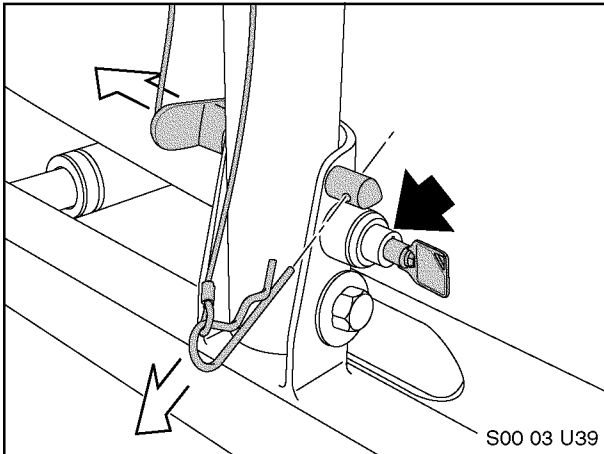

To gain access to vehicle cargo area carefully pivot arm away from vehicle as follows:

28. Unlock security lock.
29. Remove clip from "T" Handle Pin.

Caution: Before removing "T" Handle Pin make certain you have a firm grip on bike rack arm and you can support weight of load being carried.

30. Carefully remove "T" Handle Pin from arm.

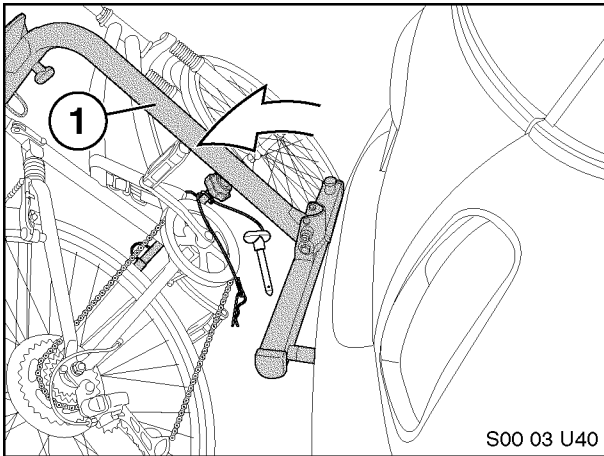

31. Carefully allow bike arm (1) to pivot rearward until pivot arm contacts stop.

To reposition bike rack in "Travel" position reverse steps listed above.

Caution: When moving pivot arm always make certain you have a firm grip on bike rack arm and you can support weight of load being carried.